

V700 SERIES AWNING (PROJECT-OUT)

FEATURES

- ◇ **Commercial Framing System**
 - 3 1/4" main frame
- ◇ **Enhanced Design**
 - Mitered and welded corners
- ◇ **Glazing**
 - 1" insulated glass specifically designed to achieve Large Missile requirements (exact make-up available upon request)
- ◇ **Integral Nailing Fin**
- ◇ **Hardware**
 - Multi-point locking system with fold-down handle to avoid interference with window blinds
 - Heavy commercial 4-bar arms
 - Low profile flat lock
- ◇ **Screen**
 - Flex Screen
- ◇ **Colors**
 - White or Sandstone vinyl (interior/exterior)

BENEFITS

- ◇ Meets ASTM 1886 (Large Missile Impact testing)
- ◇ The capacity to match exterior colors for unique project facades
- ◇ The ability to facilitate large sizes for taller and wider window openings

PERFORMANCE

- ◇ **Structural & Thermal** (test reports or thermal simulations available upon request)

Model	Awning (Project-Out)
NAFS Rating	CW-50
Structural Load P.S.F.	75.19
Air at 50 MPH (cfm/ft ²)	0.01
Water (No Penetration) P.S.F.	7.5
U-Value (ranges based on multiple Low-E/Argon combinations)	0.24-0.28
SHGC (ranges based on multiple Low-E/Argon combinations)	0.11-0.41
Missile Level	Level D
Wind Zone	Zone 4

Window test size: 48" x 32"

OPTIONS

- ◇ **Available Configurations**
 - Project-out awning
- ◇ **Muntin Choices**
 - Internal or simulated divided lites available
- ◇ **Limited Travel Hardware**
- ◇ **Screen**
 - Extruded aluminum screen frame with BetterVue™ mesh with WaterShed® technology
 - Extruded aluminum screen frame with aluminum wire mesh
 - Extruded aluminum screen frame with sunscreen mesh
 - Extruded aluminum screen frame with stainless steel 0.009" thickness mesh
- ◇ **Glazing**
 - Multiple Low-E and argon glazing choices
 - Capillary tubes
 - Wide variety of glazing, tinting and thickness options
- ◇ **Panning & Trim Choices**
 - Wide variety of panning, receptor and trim available
- ◇ **Mulling**
 - Wide variety of structural mulls
- ◇ **Colors**
 - High-performance Textured Black laminate (interior/exterior)
 - High-performance Textured Black laminate (exterior only with White vinyl or Textured Black laminate interior)
 - High-performance Textured Dark Bronze laminate (exterior only with White vinyl interior)
 - Twelve painted exterior colors (with White or Sandstone vinyl interior)
 - Unlimited custom painted exterior colors

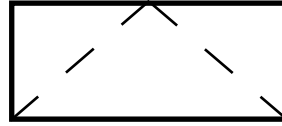

V700 Series 3 1/4" Frame Depth Awning (Project-Out)

V700 AWNING

This document contains confidential and proprietary information intended for the private use of Quaker.
 © 2016 Quaker Window Products Co., INC. All rights reserved.
 Quaker reserves the right to change any/all designs without notice. Due to periodic re-certification requirements, result shown may vary.

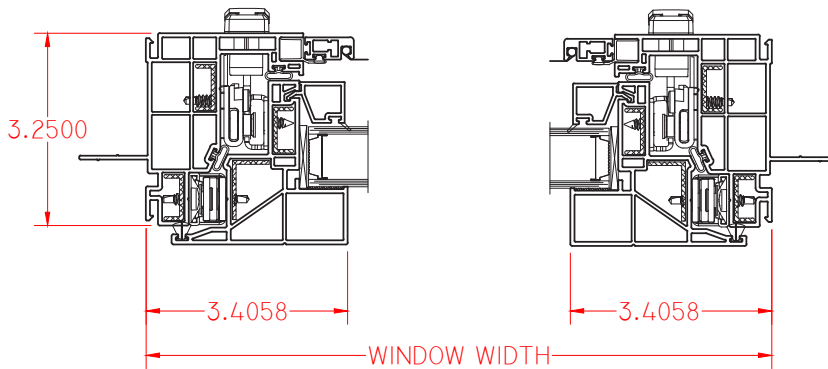

Ⓐ VERTICAL CROSS SECTION

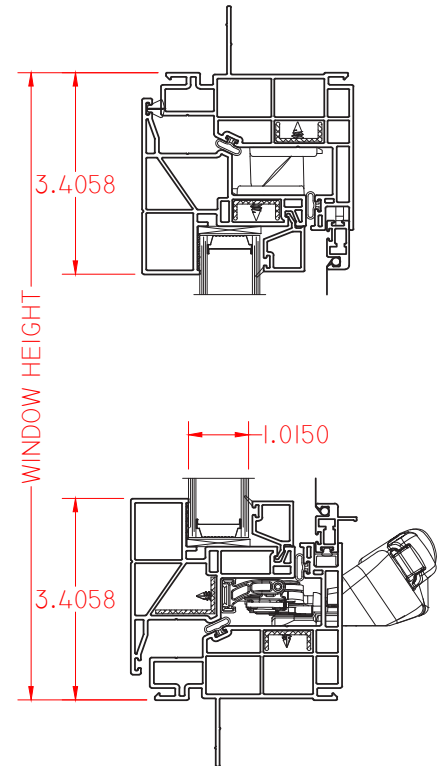
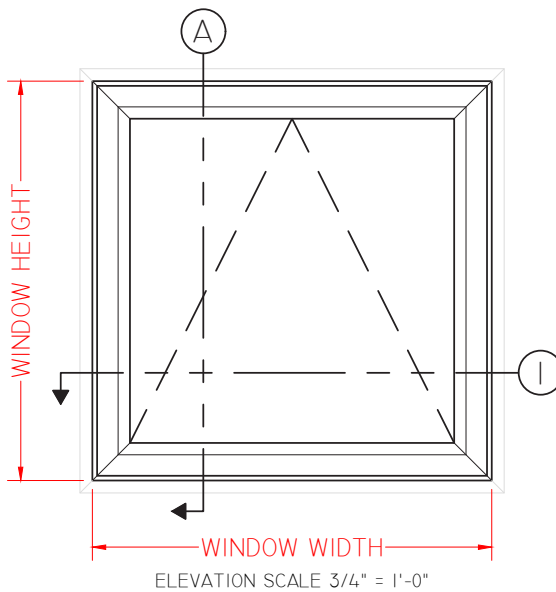

SCALE 1:3

Our products are tested to the standards of and certified by some of the foremost organizations in the fenestration industry.

